

# i- Pilot Wireless Accessory

**Do NOT replace the complete i-Pilot as a boxed marine accessory – trouble shoot and replace the defective part!**

Connect motor to the voltage appropriate (12/24/36) for the motor being serviced. For Terrova, Riptide Terrova, Ultrera, Riptide Ultrera, and Ultrax motors the motor must be deployed and the System Ready light “ON” for the motor and i-Pilot system to function.

*Make sure the i-Pilot remote and controller assemblies have the latest software downloaded.*

## TROUBLESHOOTING

*Further information for issues not specific to i-Pilot can be found in the specific model repair manuals.*

<b>Part I.</b>	<b>General Troubleshooting</b>	<b>pages 1 through 6</b>
<b>Part II.</b>	<b>Miscellaneous System Information</b>	<b>pages 7 through 9</b>
<b>Part III.</b>	<b>Remote Quick Reference Guide</b>	<b>pages 10 through 16</b>

Please note the differences in the following pictures as they will be referenced throughout this manual. These are referred to as i-Pilot remotes:



Remote for *i-Pilot 1.0*  
p/n 2994085



Remote for *i-Pilot 1.5*  
p/n 2994170 & p/n 2994171 (Ultrera)  
(Ultrera remote has trim/stow/deploy buttons)



Remote for *i-Pilot 1.6*  
p/n 2994075  
(Blue Tooth® enabled i-Pilot system)

The i-Pilot controllers are located in the top control box head. This is where the GPS receiver and compass is housed. Please note the following differences between the controller decals for i-Pilot versions 1.0, 1.5, and 1.6.



**i-Pilot 1.0**



**i-Pilot 1.5**



**i-Pilot 1.6**  
(Blue Tooth® enabled i-Pilot system)

**NOTE:** On **PowerDrive and Riptide PowerDrive** (V2 and newer), once the i-Pilot is installed the i-Pilot remote will be the only means of steering the PowerDrive motor. The corded footpedal will no longer steer the motor if the i-Pilot Controller cable is disconnected and the footpedal reconnected. To recover steering with the corded footpedal, the complete i-Pilot system would need to be un-installed and, if the motor has an AutoPilot model main control board, an original compass control board would also need to be installed.

**NOTE:** **Terrova, Riptide Terrova, Ulterra, Riptide Ulterra, and Ultrex** motors communicate with any connected accessory via a microprocessor-based network. The failure of *any* installed network accessory can result in motor malfunction. Disconnect all accessories other than the i-Pilot when diagnosing the motor. If the problem is corrected, then reconnect each accessory one at a time to isolate which component caused the issue.

## Part I. General Troubleshooting

*Click on blue Case to jump to the linked discussion/resolution:*

**Case I.** The motor is making erratic steering corrections while in AutoPilot, Spot-Lock or Track to Start/End.

**Case II.** The boat doesn't seem to keep close enough to the recorded Spot-Lock location.

**Case III.** When in Advanced AutoPilot in strong winds, there is quite a bit of back and forth movement in the boat.

**Case IV.** When in Advanced AutoPilot in strong winds, there is quite a bit of back and forth movement in the boat.

**Case V.** i-Pilot won't let me turn on certain features like Advanced AutoPilot, Record, Track to Start/End, or Spot-Lock.

**Case VI.** The i-Pilot GPS-based features drop out when the motor speed setting is increased.

**Case VII.** While in Track to Start/End the propeller suddenly stopped.

**Case VIII.** While in Record mode, the recording suddenly stopped.

**Case IX.** When a button on the 1.5 remote is pressed no icons are displayed on the remote LCD screen. *(refer to pictures on prior page for remote versions)*

**Case X.** When any button on the 1.0 remote is pressed nothing happens. *(refer to pictures on prior page for remote versions)*

**Case XI.** When buttons on the 1.0 remote are pressed some of them work and others do not, but all buttons "feel" the same. *(refer to pictures on prior page for remote versions)*

**Case XII.** When a specific button on the 1.0 remote is pressed nothing happens. *(refer to pictures on prior page for remote versions)*

**Case XIII.** The i-Pilot 1.0 or 1.5 remote displays an “F” on the LCD screen OR the i-Pilot 1.6 remote displays “Motor Error”. *(refer to pictures on first page for remote versions)*

**Case XIV.** The screen on the 1.6 remote displays “RF error”. *(refer to pictures on first page for remote versions)*

**Case XV.** Pressing any button on the 1.0 or 1.5 remote causes all the icons to come on for a few seconds and then turn off, OR the screen on the 1.6 remote reads “Motor Not Found” when the remote is on. *(refer to pictures on first page for remote versions)*

**Case XVI.** The remote LCD backlighting will not come on.

**Case XVII.** Customer complaint that the battery in the i-Pilot remote drains quickly.

**Case XVIII.** There is moisture in the LCD window or the remote case.

**Case XIX.** On PowerDrive / Riptide PowerDrive models, the steering does not work properly or at all following i-Pilot installation.

**Case XX.** The heading sensor calibration failed. (i-Pilot 1.6 only)

## **Part II. Miscellaneous System Information**

- Accuracy
- Battery Life
- Battery Replacement
- Remote Pairing / Learning
- Audio Modes

## **Part III. Remote Quick Reference Guide**

- Quick Reference Guide 1.6
- Quick Reference Guide 1.5
- Quick Reference Guide 1.0

# i- Pilot Wireless Accessory

## Part I. General Troubleshooting

### **Case I. The motor is making erratic steering corrections while in AutoPilot, Spot-Lock, or Track to Start/End.**

- Step 1.** Check all electrical connections and battery condition to ensure that the proper voltage is supplied to the motor. Consistent voltage is critical to ensure the built-in compass is working correctly. (The i-Pilot system uses an internal compass to know which direction the controller and GPS receiver is pointing.) A load test of the battery should be performed to verify the battery(s) condition; a simple voltage check is not diagnostic.
- Step 2.** Be sure to keep all ferrous metallic objects away from the i-Pilot Controller as they will have an impact on the built-in compass. Such objects include: anchors, metal framework, etc...
- Step 3.** Check to ensure proper motor leadwire routing in control box.
- A.** The red and black motor leads in the control box should be routed on the coil cord half of the control box. (Away from the compass of the i-Pilot controller.)
  - B.** The red and black motor leads in the control box should be twisted around each other to cancel out the magnetic field created around these wires when the motor is running.
    - B-1.** If the motor shaft was shortened, the brush leadwire should also be cut back the same length.
    - B-2.** If the motor shaft was shortened and the motor has a built-in transducer, the extra transducer cable should be routed out of the control box and down the coil cord.

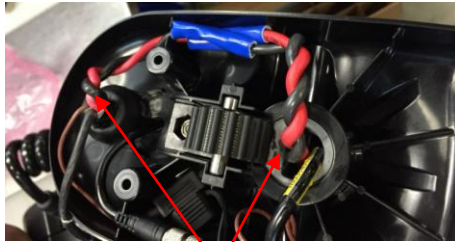

(Note that the red/black wires should be twisted three times on both the coil cord and brush leadwire sides and then the insulator or shrink tube is slid in place over the spade connectors. This picture shows an Ultrerra, but the wire routing is similar and critical for all motors with i-Pilot.)

- Step 4.** The i-Pilot GPS-based functions are dependent on having good GPS signals (Advanced AutoPilot, Spot-Lock, Track to Start/End). Check to make sure that a good signal is being received and that the GPS signal strength indicator on the i-Pilot remote is showing at least one (1) bar. See **Case V** below.
- Step 5.** If the motor with i-Pilot being serviced is a *2017 or later model (Bluetooth version)*:
- A.** If motor has a separate *Heading Sensor*, it is very important that the Heading Sensor is properly installed and has gone through the calibration and offset procedures. While the Heading Sensor is there to help with navigation performance; if it is not properly installed/calibrated it can have a negative influence.
    - A-1.** Temporarily remove power from the Heading Sensor and see how Spot-Lock performance is impacted. If performance is improved, suspect that the Heading Sensor was improperly installed. (The Heading Sensor contains a compass that detects a magnetic field so it should not be installed near ferrous metals or wires that handle large currents, such as batteries, power cables, or speakers.) The Heading Sensor will not lose its pairing to the i-Pilot system when it is powered down.
  - B.** *Boat Scale* can be adjusted on the i-Pilot remote.
    - B-1.** Ideal installation for a trolling motor is to have the proper amount of thrust for the size of the boat. If the motor thrust is not properly matched to the boat size, Boat Scale can be used to compensate for the mismatch. The default is zero, assuming that the boat and trolling motor thrust are properly matched. For an installation where the motor thrust is undersized for the boat, increase the Boat Scale. For installation where the motor thrust is oversized for the boat, decrease the Boat Scale.

**Step 7.** If, after following the previous steps, the problem of erratic steering persists replace the i-Pilot Controller.

## **Case II. The boat doesn't seem to keep close enough to the recorded Spot-Lock location.**

**Step 1.** Verify the trolling motor batteries are sufficiently charged.

**Step 2.** Check for weeds wrapped around and under the prop.

**Step 3.** In more extreme wind and current conditions, the boat will tend to stabilize a little downwind from the intended location. Relock the location the same distance upwind and expect that the boat will drift some in the downwind direction.

**Step 4.** See Case I.

## **Case III. When in Advanced AutoPilot in strong winds, there is quite a bit of back and forth movement in the boat.**

**Step 1.** While Advanced AutoPilot will keep your boat on a true heading, it may be at the expense of the boat having to continuously move to get back on the correct course. In these extreme conditions you may be better off using Legacy AutoPilot and correcting for the wind manually.

**Step 2.** See Case I.

## **Case IV. Under AutoPilot mode, I have Advanced selected as the default mode. However, when I engage AutoPilot, it goes into Legacy AutoPilot instead of Advanced.**

**Step 1.** If the GPS signal strength indicator shows no bars or is flashing, then Link will automatically engage Legacy AutoPilot regardless of the Mode selected. Wait for your GPS signal strength to reach at least one bar, then re-engage AutoPilot.

## **Case V. i-Pilot won't let me turn on certain features like Advanced AutoPilot, Record, Track to Start/End, or Spot-Lock.**

**Step 1.** Verify that the GPS signal strength icon on the remote's LCD shows at least one bar. If there are no bars, i-Pilot will not allow these GPS-based features to be enabled.



**This GPS icon should have 1-4 bars next to it displaying GPS signal strength.  
If there are no bars present then all GPS features will be disabled.**

- A. Ensure that the motor has a clear view of the sky so it can obtain GPS reception. (Motor cannot be indoors or under a roof, bridge, or tree canopy.)
- B. Ensure the minimum voltage requirements at the motor are met.
- C. Replace the i-Pilot Controller.

### **Case VI. The i-Pilot GPS-based features drop out when the motor speed setting is increased.**

**Step 1.** Suspect a low voltage situation.

- A. Inspect all battery connections, trolling motor plug (if installed), and any butt splice connections in battery leadwire for corrosion and security. Use of inadequate gauge wire in boat or any leadwire extension can result in voltage drop / low voltage to the motor; as can an inadequate or a corroded plug / plug receptacle.
- B. Ensure the minimum voltage requirements at the motor are met.

### **Case VII. While in Track to Start/End the propeller suddenly stopped.**

**Step 1.** Verify you did not accidentally enable another automatic feature such as AutoPilot or Spot-Lock.

**Step 2.** The Arrival Mode may be set to OFF. When the End or Start point of an iTrack is reached the i-Pilot Link will automatically cancel iTrack navigation. Depending on the Arrival Mode chosen, the motor will turn off, go into Spot-Lock, or go into AutoPilot. See i-Pilot Link User Manual for more information.

### **Case VIII. While in Record mode, the recording suddenly stopped.**

**Step 1.** You may have reached the two-mile limit for recording a track.

### **Case IX. When a button on the 1.5 remote is pressed no icons are displayed on the remote LCD screen.**

**Step 1.** Use a coin, (a quarter works well), to remove the battery cover on the back side of the remote. Insert coin in slot and rotate the cover about 60° counterclockwise to disengage the cover locking tabs from the case back. Turn the remote over and then the cover and CR2450 battery should fall out the back of the remote.

**Step 2.** Test the remote battery voltage. A good battery will have at least 2.9 volts. Replace the battery, if required, and reassemble battery and cover into the remote.

- A. Retest remote for function and icon display. If no display is noted, replace the remote (p/n 2994170 or 2994171 for Ulterra).

### **Case X. When any button on the 1.0 remote is pressed nothing happens.**

**Step 1.** Open the remote case assembly by removing the six screws on the back side of the remote.

**Step 2.** Check voltage of the battery in the remote. A good battery will read at least 2.9 volts. Replace the battery and retest, as necessary.

**NOTE:** Care must be used when reassembling the remote case. Be sure to re-install the screws using the same threads initially “cut” when the screws were first installed. The screws should be torqued to about 6 inch-pounds to ensure proper resealing of the remote assembly.

**Step 3.** If the battery voltage checked okay, check the security of the battery holder to the remote’s circuit board. If B+ or B- battery connections are loose or if the battery holder is loose from the circuit board replace the remote assembly.

**Step 4.** If the customer reported seeing “moisture” in the LCD window and the remote does not respond to any button press then water may have gotten inside the sealed remote enclosure and shorted out the microcircuit on the board. Replace remote assembly.

### **Case XI. When buttons on the 1.0 remote are pressed some of them work and others do not, but all buttons “feel” the same.**

**Step 1.** Open the remote case assembly by removing the six screws on the back side of the remote. Visually inspect the dome switches on the front side of the remote circuit board. If any dome switch is found to be flattened or collapsed, replace the remote. If the dome switches are fine, but a plunger array pin is bent or broken, replace the plunger array (p/n 2378451).

### **Case XII. When a specific button on the 1.0 remote is pressed nothing happens.**

**Step 1.** If the button pressed feels “soft” or different from the other buttons, the plunger array (p/n 2378451) has a broken pin and needs to be replaced. Open the remote case assembly by removing the six screws on the back side of the remote. When replacing a broken plunger array, visually inspect the dome switches on the front of the remote circuit board. If any dome switch is flattened or collapsed, replace the remote assembly.

### **Case XIII. The i-Pilot 1.0 or 1.5 remote displays an “F” on the LCD screen OR the i-Pilot 1.6 remote displays “Motor Error”.**

**Cause:** This indicates that the i-Pilot Controller is not able to communicate with the motor control board. This error will not display on PowerDrive motors.

**Step 1.** Cycle Power to the motor.

- A. On Terrova/Riptide ST from 2016 and earlier (non-Blue Tooth) the main control board only looks for accessories when it first powers up; if the i-Pilot began communicating after initial power up or was installed while powered up, the control board will not recognize it until the next time it powers up. This step may resolve the issue.
- B. Re-test for proper remote function. If the “F” or “Motor Error” is not displayed the i-Pilot is functioning properly. If the “F” or “Motor Error” is still present proceed to **Step 2**.

**Step 2.** Disconnect the i-Pilot system and test the motor for full function using foot pedal.

- A. If the motor fails to function properly using a foot pedal, resolve all motor issues then retest remote function prior to proceeding to **Step 3**.
- B. If the “F” or “Motor Error” message is still present and the motor functions correctly via foot pedal proceed to **Step 3**.

**Step 3.** Disconnect Power to the motor.

- A. Check the i-Pilot coil cord network plug connection in the control box/head for corrosion and verify that is fully connected (connected properly there should be no yellow visible between the male and female plug ends).
- B. Check the network plug(s) at the Control Board; on Terrova/Riptide ST motors that have CoPilot installed on the alternate network plug disconnect that CoPilot (i-Pilot disables CoPilot function, but if there is a fault in a connected CoPilot it may disable network communication). Verify that the connection to the coil cord is fully seated.
- C. Reconnect power and retest.
- D. If “F” or “Motor Error” is no longer showing a loose connection or faulty CoPilot was the cause for the error. If the “F” or “Motor Error” message is still displayed Proceed to **Step 4**. If a network plug that was previously connected is going to be left disconnected install a 2320203 Cap Plug on that plug prior to returning the motor to the customer.

**Step 4.** Disconnect power to the motor.

- A. Disconnect the network cable at both ends of the coil cord and test continuity through each of the 5 pins. If no continuity is present end to end, or any pin has continuity to one of the other pins replace the coil cord.
- B. If there is an unused network accessory plug on the control board connect the coil cord to that plug and retest the system. i-Pilot installed motors will never have a use for a second network plug, if this connection does not display “F” / “Motor Error” this works as a complete repair.
- C. If the “F” or “Motor Error” Message is still displayed replace the i-Pilot Controller (head).

### **Case XIV. The screen on the 1.6 remote displays “RF error”.**

**Cause:** This indicates a fatal error with the remote. The remote needs to be replaced with p/n 2994075.

**Case XV. Pressing any button on the 1.0 or 1.5 remote causes all the icons to come on for a few seconds and then turn off, OR the screen on the 1.6 remote reads “Motor Not Found” when the remote is on.**

**Step 1.** Verify power is supplied to the i-Pilot Controller.

- A. For PowerDrive Motors press the “Push-to-Test” battery meter to verify voltage to the motor and check the connection to the footpedal plug is secure
- B. For all other motors verify the motor is turned on, a system ready or power light will be illuminated (on the base of the motor on all Terrova/Ultrerra Models, on the footpedal on Ultrex).

**Step 2.** Re-pair/re-learn the remote to the Controller. (See **Part II. Miscellaneous System Information**)

**Step 3.** Turn the system OFF and then back ON (for PowerDrive models, disconnect then reconnect power).

**Case XVI. The remote LCD backlighting will not come on.**

**Step 1.** Check if the low battery indicator icon is on. Backlighting is disabled when a low battery level is detected.

Replace the battery.

- A. The backlight will not come on if the remote is not currently communicating with the i-Pilot Controller.

**Case XVII. Customer complaint that the battery in the i-Pilot remote drains quickly.**

**NOTE:** This cannot be due to a problem with the motor or the i-Pilot Controller.

**Step 1.** If this is an i-Pilot remote version 1.0, the customer may be misunderstanding the “low battery” icon.

- A. This icon is not a gauge showing the voltage left in the battery. It is simply a warning icon.
- B. On early models, when a customer “wakes up” the remote by pressing any button, all of the icons were briefly displayed. The “low battery” icon was included in this start-up display. After the start-up display, the “low battery” icon was only shown on the LCD if the voltage in the remote’s battery was actually low. (A software change in later models addressed this by removing the “low battery” icon from the initial startup display.)

**Step 2.** Turn the backlight off to significantly increase battery life.

**Step 3.** Constantly sending signals with the remote will run the battery down. We have heard a few complaints where the customer sat on the remote (or somehow otherwise engaged a remote button) thus sending constant signals.

**Case XVIII. There is moisture in the LCD window or the remote case.**

**Step 1.** Remove the battery cover on the back side of the remote to examine the battery cover o-ring/gasket and cover locking tabs for damage. If either is damaged you will need to replace the cover.

**Step 2.** Check the battery and battery contact for corrosion.

- A. If corrosion is noted on the battery(s) replace it/them.
- B. If corrosion is noted on the battery contacts in the remote clean them, as necessary.

**Step 3.** Prior to installing the cover, allow the remote to dry out by placing it in a warm dry location for several hours. If necessary use dry, low pressure air to ventilate the remote case.

- A. Reassemble the remote and test.
- B. If the remote ceases to function after this then the microcircuits or components on the remote circuit board have shorted out and the remote will need to be replaced.

### **Case XIX. On PowerDrive / Riptide PowerDrive models, the steering does not work properly or at all following i-Pilot installation.**

- Step 1.** Verify that the black and white steering motor wires are properly connected to the black and white wires coming from the i-Pilot Controller cable.
- A.** Re-test steering. If steering fails to function, proceed to **Step 2**.
- Step 2.** Disconnect black and white steering motor / drive housing leads and connect 12 volts directly to those leads.
- A.** If the drive housing does not turn, open the drive housing to inspect the steering motor and drive housing gears for binding and/or lack of lubrication. Service the drive housing as needed to correct the malfunction.
  - B.** If the drive housing does turn, proceed to **Step 3**.
- Step 3.** Test output voltage to the steering motor at the black and white i-Pilot Controller cable wires by connecting a voltmeter to the wires. With proper voltage supplied to the motor send a steering command from the remote. Observe the voltmeter for voltage.
- A.** If no voltage is noted when steer left or right button is pressed, the i-Pilot Controller may be at fault. Verify that 12 volts is being provided to the i-Pilot Controller by pressing and holding the “learn” button. If a steady tone is heard, power is being supplied to the i-Pilot Controller, but no steering output is present when the steering command is sent from the remote. The i-Pilot Controller is at fault and needs to be replaced.

### **Case XX. The heading sensor calibration failed. (i-Pilot 1.6 only)**

- Step 1.** The heading sensor needs to be located in a place where it is not subject to magnetic interference, as it is an electronic compass. Ensure that the heading sensor is mounted at least 24 inches from magnetic or ferrous materials or anything that may create a magnetic interference. Some of which may include: base of the trolling motor, anchors, metal railings, speakers, radios, and trolling motor battery leadwires. It must be mounted on a flat, horizontal surface with the arrow on the sensor parallel to the boat’s keel. It should have a line of sight to the i-Pilot Link Controller for best operation.

## Part II. Miscellaneous System Information

### ACCURACY

The accuracy and responsiveness with which i-Pilot controls your boat is highly dependent upon many variables. A few of these variables and their general effects on responsiveness and accuracy are given below:

Variable	Effect
Ratio of motor thrust to boat weight	Excessive thrust on a smaller boat can cause i-Pilot to over correct. Not enough thrust on a large boat can cause i-Pilot to respond slowly.
Wind	Excessive wind and/or current can reduce i-Pilot's positioning accuracy.
GPS signal strength	The greater number of GPS signal bars the greater the accuracy.
Trolling motor battery power level	A fully charged battery will give the best performance.

### BATTERY LIFE

Remote battery life is subject to frequency of use and is especially impacted by how often and bright the LCD backlight is used. When the remote battery is low, the “**Remote Battery Low**” icon will appear on the remote LCD. The “**Backlight**” button will be disabled when the “**Remote Battery Low**” icon is displayed to conserve battery power.









### BATTERY REPLACEMENT

*For i-Pilot 1.6:* The Remote is powered by three alkaline AAA batteries.

*For i-Pilot 1.0 & 1.5 systems:* **NOTE:** Panasonic brand batteries will not work with the version 1.0 i-Pilot remote! Make sure hands are clean, dry and static free. Discharge any static electricity by touching a metal object that is grounded. Replace with a new CR2450 coin cell battery.

### REMOTE PAIRING / LEARNING

*For i-Pilot 1.6 systems:* An i-Pilot controller may pair up to 5 remotes. These 5 remotes can be a combination of standard i-Pilot Link remotes and Micro remotes. Any additional remotes can be paired using the following steps. Once the maximum number of remotes have been paired, the controller will start replacing the oldest paired remote in memory with the new remote.

- Step 1.** Power up the trolling motor. Then turn the remote ON by pressing and releasing the  button. Agree to the disclaimer by pressing the Right Softkey . If the remote was already ON, press the Home  button.
- Step 2.** Use the Menu Up  and Menu Down  buttons to find the System menu at the bottom of the display screen. **NOTE:** Make sure the remote stays within range of the Control head during the pairing process.
- Step 3.** Use the Right Softkey  to select the System menu.
- Step 4.** Use the Menu Up  and Menu Down  buttons to find the Pair option.
- Step 5.** Before selecting the Pair Option, locate the Pair Button on the top of the Control Head. Press and hold the Pair button. A consistent tone will be emitted from the Control Head.
- A.** If no tone is emitted, ensure motor is connected to appropriate voltage and powered ON, if applicable.
    - A-1.** Test the system with a known good footpedal (on PowerDrive systems this means un-installing the i-Pilot system).
      - a.** If the system works with the footpedal, replace the i-Pilot Controller (head assembly).
      - b.** If the system does not work with the footpedal, review the specific chapter of the repair manual regarding the specific model you are servicing.
- Step 6.** On the remote, use the Ok  button to select the Pair option from the System menu. The Remote will scan for the motor. Once successfully paired, 3 longer beeps will be emitted from the Control head and the remote will be paired.
- A.** If the Pair process does not complete, redo procedure with a known good Remote.
    - A-1.** If the known good remote successfully Pairs with the Controller, replace consumer's remote
    - A-2.** If the known good remote does not successfully Pair with the Controller, replace Controller.

**For i-Pilot 1.0 & 1.5 systems:** A remote can only be learned to one Controller at a time. A Controller can have an unlimited number of remotes learned to it. The top of the Controller has a single learn button to allow additional remotes to be added to the system.

**Step 1.** Power up the trolling motor. Press and hold the learn button down on the Controller. A steady audio tone will be heard while holding this button.

**A.** If no tone is emitted, ensure motor is connected to appropriate voltage and powered ON, if applicable.

**A-1.** Test the system with a known good footpedal (on PowerDrive systems this means un-installing the i-Pilot system).

**a.** If the system works with the footpedal, replace the i-Pilot Controller (head assembly).

**b.** If the system does not work with the footpedal, review the specific chapter of the repair manual regarding the specific model you are servicing.

**Step 2.** While holding the learn button down push any button on the remote being programmed. Three short chirps will be heard when the remote is successfully learned.

### AUDIO MODES

**For i-Pilot 1.6 systems:** The i-Pilot controller in the Control Head contains an internal speaker which can be configured to work in two different audio modes. The unit is factory set to Audio Mode 2. To select the different audio modes press the Home  button, then from the Home screen go to: Settings>Options>Audio Mode

Review the modes below to determine what audio patterns are caused by conditions in each audio mode.

Audio Pattern	What Condition Causes Audio Pattern	Audio Mode
Error	Attempting to enable a GPS feature when no signal strength bars are shown.	Mode 2
	Attempting to replay an iTrack or recall a Spot-Lock location when the boat is beyond the minimum required distance.	Mode 2
	The Momentary Button on the foot pedal is pressed, for applicable motors, and a remote button press attempts to override it.	Mode 2
	When GPS signal strength goes to no bars while in a GPS-based mode.	Mode 2
	When overriding navigation by steering with the foot pedal or remote.	Modes 1 and 2
Single Beep	Speed + (When less than maximum speed.)	Mode 2
	Speed - (When greater than speed 0.)	Mode 2
	Enable High Speed Bypass.	Mode 2
	Switch to Audio Mode 1	Modes 1 and 2
	Manual Prop on	Mode 2
	Enabling or disabling Record, GO TO, AutoPilot, Cruise Control or Spot-Lock.	Mode 2
Double Beep	Disable High Speed Bypass.	Mode 2
	Switch to Audio Mode 2	Modes 1 and 2
	Manual Prop off	Mode 2
3 longer Beeps	Pair successfully completed	Modes 1 and 2
4 Short Beeps	Startup	Modes 1 and 2
Steady Tone	Pair button is pressed.	Modes 1 and 2
High-Low, High-Low, High-Low	End of iTrack attained during track playback (in conjunction with canceling mode and turning the prop off)	Mode 2

**For i-Pilot 1.0 & 1.5 systems:** The i-Pilot Controller contains an internal speaker which can be programmed to work in two different audio modes. The speaker is programmed to operate in audio mode 1 from the factory. To enable different audio modes the hold “+” button and the “-” button down at the same time for three seconds.

For an explanation of each audio mode and their sounds see the table below:

<b><u>WHAT CONDITION CAUSES IT</u></b>	<b><u>AUDIO MODE</u></b>	<b><u>AUDIO PATTERN</u></b>
Start up	Modes 1 and 2	4 short beeps
Manual prop on	Mode 2	single beep
Manual prop off	Mode 2	double beep
Speed + (when less than max speed)	Mode 2	single beep
Speed - (when greater than speed 0)	Mode 2	single beep
High speed bypass enable	Mode 2	single beep
High speed bypass disable	Mode 2	double beep
Button press for any of these (enable or disable): REC, Pause, Track to Start, Track to End, AutoPilot, Cruise Control, Spot-Lock, Spot-Lock Recall	Mode 2	single beep
Moving more than a quarter mile from the last track point while in Record Pause mode	Mode 2	error
When GPS signal strength goes to no bars while in a GPS-based mode	Mode 2	error
Attempting to enable a GPS feature when no signal strength bars are shown	Mode 2	error
Attempting to replay a Track or recall a Spot-Lock location when the boat is beyond the minimum distance	Mode 2	error
MOM button on the footpedal is pressed and a remote button press attempts to override it	Mode 2	error
End of track attained during track playback (in conjunction with canceling mode and turning the prop off)	Mode 2	high-low, high-low, high-low
Switch to audio Mode 1	Modes 1 and 2	single beep
Switch to audio Mode 2	Modes 1 and 2	double beep
Learn button is pressed	Modes 1 and 2	steady tone
Learn successfully completed	Modes 1 and 2	4 longer beeps

## Part III. Remote Quick Reference Guide

### i-Pilot remote 1.6

## QUICK REFERENCE GUIDE

COMPATIBLE WITH ALL BLUETOOTH® ENABLED I-PILOT SYSTEMS

### REMOTE



Scan to view the complete i-Pilot Owner's Manual online.

### Menu Control Buttons

-  **Home**  
Pressing this button will always bring up the Home Screen.
-  **Ok**  
Press to accept selections. Press to power remote on. Press and hold for 3 seconds to power remote off.
-  **Left Softkey & Right Softkey**  
Buttons change function based on the mode of operation and which screen is presently displayed. Softkey Labels at the bottom of the display screen indicate current function.
-  **Menu Up & Menu Down**  
Used to navigate Softkey Labels and menus.

### Manual Control Buttons

-  **Speed Down**
-  **Steer Left**
-  **Speed Up**
-  **Steer Right**
-  **Prop On/Off**
-  **High Speed Bypass**  
Double press to engage.



### Navigation Buttons

-  **GO TO**  
Opens the list of Spot-Locks and iTracks that are within navigable range.
-  **Cruise Control**  
Press to enable Cruise Control.
-  **Spot-Lock**  
Press to enable Spot-Lock.
-  **AutoPilot**  
Press to enable AutoPilot or Advanced AutoPilot.

## Quick Reference Guide 1.6

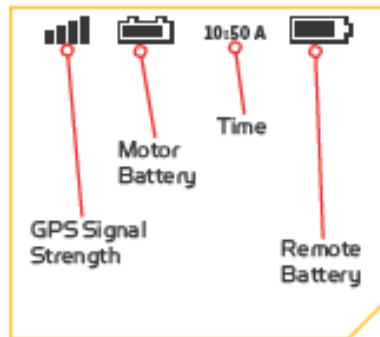





### HEADER



-  **GPS Signal Strength**  
Shows the level of GPS signal strength. If no bars appear, no GPS signal is detected.
-  **Motor Battery** ♦ ■  
Displays the battery level of the motor
- 10:50 A **Time**  
Displays the current time.
-  **Remote Battery**  
Displays the battery level of the remote.

### ICONOGRAPHY

-  **Spot-Lock**  
Displays when Spot-Lock is engaged.
-  **Spot-Lock Jog**  
Displays when Spot-Lock is engaged and the motor is communicating with a Heading Sensor.
-  **Legacy AutoPilot**  
Displays when AutoPilot is engaged and the AutoPilot Mode is set to Legacy.
-  **Advanced AutoPilot**  
Displays when AutoPilot is engaged and the AutoPilot Mode is set to Advanced.
-  **Record**  
Displays when an iTrack is being recorded.
-  **iTrack**  
Displays when an iTrack is being navigated.
-  **Prop Lockout** ♦  
Displays when the Prop is locked during certain functions.
-  **Trim** ♦  
Displays when Trim is being adjusted.
-  **Brightness**  
Displays when screen brightness is being adjusted.

-  **Prop**  
Displays when the Prop is enabled. Rotates when the Prop is on. Blinks when a mode of navigation is used that requires the prop to be enabled.
-  **Prop Speed**  
Displays the current Prop Speed. Can be adjusted in 1/2 speed increments between 0 and 10.
-  **Ground Speed**  
Displays the current speed over ground.
-  **Cruise Control**  
Displays the Target Speed when Cruise Control is engaged.
-  **Lock**  
Displays when the Remote is locked.
-  **Scroll Up & Down**  
Displays when the softkey labels at the bottom of the display screen have more options available.







♦ Only available with Ultrera.

■ Only available with Ultrax.





## Quick Reference Guide 1.6

### SPOT-LOCK



#### ▶ ENGAGING SPOT-LOCK

1. Press the Spot-Lock  button on the remote.
2. The information for the temporary Spot-Lock location will show up on the display screen. Use the Menu Up  and Menu Down  buttons to find the Save softkey label at the bottom of the display screen. To save the Spot-Lock, press the Left Softkey  to open the Save menu.
3. The Save menu brings up a list of Spot-Locks. Use the Menu Up  and Menu Down  buttons to select one of the Spot-Lock memory locations. Press the Left Softkey  to Save the Spot-Lock into the selected memory location.

#### ▶ DISENGAGING SPOT-LOCK

1. When Spot-Lock is engaged, press the Spot-Lock  button to disengage Spot-Lock, or use the Menu Up  and Menu Down  buttons to find the Cancel softkey label at the bottom of the display screen. Use the Right Softkey  to select Cancel.





#### ▶ RE-ENGAGE A SAVED SPOT-LOCK

1. Manually navigate the boat to within a quarter mile of a saved Spot-Lock location. Due to safety reasons, i-Pilot will not re-engage a saved Spot-Lock location greater than a quarter mile away.
2. Press the GOTO  button on the remote.
3. The Spot-Lock menu will appear on the display screen. Use the Menu Up  and Menu Down  buttons to scroll to a saved Spot-Lock location in the menu.

4. Press the Ok  button to select a saved Spot-Lock location.



#### ▶ SPOT-LOCK JOG

(Heading Sensor required.)

1. To engage Spot-Lock Jog, first engage Spot-Lock. Use the Speed Down  (jog backward), Speed Up  (jog forward), Steer Left  (jog left), and Steer Right  (jog right) buttons to jog the Spot-Lock location 5 feet in the selected direction from the current Spot-Lock location.

### CRUISE CONTROL

#### ▶ ENGAGING CRUISE CONTROL

1. Press the Cruise Control  button on the remote.
2. The Target Speed will appear on the display screen. Press the Speed Down  or Speed Up  buttons to adjust the Target Speed.

#### ▶ DISENGAGING CRUISE CONTROL



1. When Cruise Control is engaged, press the Cruise Control  button on the remote to disengage Cruise Control.

### HIGH SPEED BYPASS

#### ▶ ENGAGING HIGH SPEED BYPASS

1. Double press the High Speed Bypass  button.
2. The Prop Speed will automatically go to speed 10.

#### ▶ DISENGAGING HIGH SPEED BYPASS

1. When High Speed Bypass is engaged, press the High Speed Bypass  button on the remote to disengage High Speed Bypass, or press the Speed Down  button.

## Quick Reference Guide 1.6

### AUTOPILOT

#### ▶ ENGAGING AUTOPILOT OR ADVANCED AUTOPILOT







1. Press the AutoPilot  button on the remote.
2. The AutoPilot or Advanced AutoPilot icon will display on the screen.
3. To adjust the desired heading, manually steer the motor to the new heading. i-Pilot will automatically lock onto the new heading.





#### ▶ DISENGAGING AUTOPILOT OR ADVANCED AUTOPILOT

1. When either AutoPilot mode is engaged, press the AutoPilot  button on the remote to disengage AutoPilot.







### ITRACK

#### ▶ RECORDING AN ITRACK



1. Use the Menu Up  or Menu Down  buttons to find the Record softkey label at the bottom of the display screen.
2. Press the Left Softkey  to select the Record menu.
3. The Record menu brings up a listing of iTracks. Use the Menu Up  and Menu Down  buttons to scroll to one of the iTrack memory locations.
4. Press the Ok  button to select an iTrack memory location. Once a location is selected, the current location of the boat becomes the To Start location of the iTrack being recorded.
5. Navigate the boat along the desired path or course. AutoPilot and/or Cruise Control can be used while recording an iTrack.

6. To stop recording an iTrack, use the Menu Up  or Menu Down  buttons to find the Stop softkey label at the bottom of the display screen.
7. Use the Left Softkey  to select Stop.
8. The recording will end automatically if the two-mile distance limit is reached for the iTrack or if the Spot-Lock  or GO TO  button is pressed.

#### ▶ NAVIGATING AN ITRACK

1. Manually navigate the boat to within a quarter mile of the saved iTrack. Due to safety reasons, i-Pilot will not re-engage a saved iTrack greater than a quarter mile away.
2. Press the GO TO  button on the remote. The remote default is to first bring up saved Spot-Locks. Press the Right Softkey  to bring up saved iTracks.
3. Use the Menu Up  or Menu Down  buttons to select an iTrack to navigate.
4. Using the Left Softkey  or Right Softkey  select the softkey label to either go To Start or To End. The boat will navigate to the closest point on the iTrack and then navigate To Start or To End depending on the selection made until it reaches that point.

#### ▶ REVERSE AN ITRACK

1. The direction that the iTrack is being navigated can be reversed while the GO TO action is taking place. Use the Menu Up  or Menu Down  buttons to find the Reverse softkey label at the bottom of the display screen. Use the Left Softkey  to select Reverse.

## i-Pilot remote 1.5

# REMOTE CONTROL QUICK REFERENCE GUIDE

### MANUAL CONTROL

- Steer Left**
- Steer Right**
- Prop On/Off**
- Speed Down**
- Speed Up**
- High Speed Bypass**  
Toggles the motor speed between its current setting and speed 10.
- Backlight**  
Turns the remote LCD backlighting on for six seconds.
- Keypad Lock/Unlock**  
To lock or unlock the keypad press and hold the backlight button for 3 seconds.

### CRUISE CONTROL/AUTOPILOT

- Advanced AutoPilot and AutoPilot**  
Turns Advanced AutoPilot on and off when pressed once. Turns AutoPilot on when held for two seconds.
- Cruise Control**  
Turns cruise control on and off using the current GPS speed as the target speed.

### TRACKS

- Track to End**  
Navigates to the nearest location on a previously recorded track and follows it to its end.
- Track to Start**  
Navigates to the nearest location on a previously recorded track and follows it to its start.
- Track Record**  
Starts and ends the recording of a track to a selected memory location.
- Record Pause/Escape**  
Pauses the recording of a track and then resumes the recording when pressed again.

### SPOT LOCK

- Spot Lock**  
Turns spot lock on and records it to a memory location.
- Spot Lock Recall**  
Recalls a spot lock location from memory and turns spot lock on.

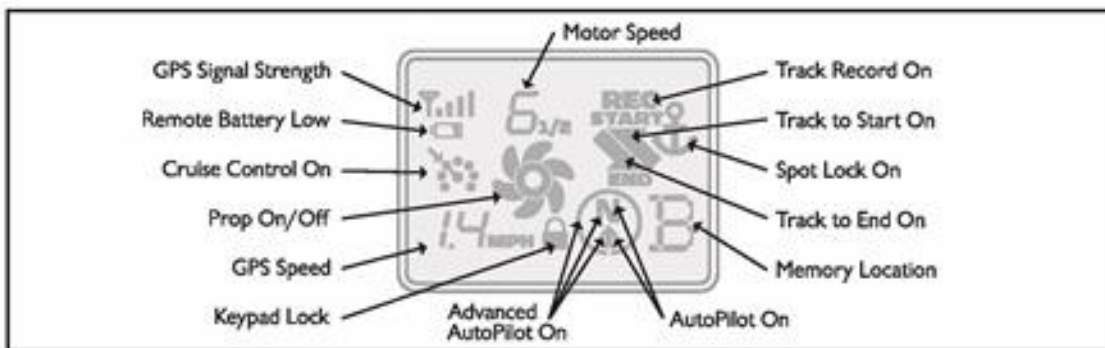

## i-Pilot remote 1.0

### REMOTE CONTROL QUICK REFERENCE GUIDE

#### MANUAL CONTROL

- Steer Left**
- Steer Right**
- Prop On/Off**
- Speed Down**
- Speed Up**
- High Speed Bypass**  
Toggles the motor speed between its current setting and speed 10.
- Backlight**  
Turns the remote LCD backlighting on for six seconds.

#### CRUISE CONTROL/AUTOPILOT

- Advanced AutoPilot and AutoPilot**  
Turns Advanced AutoPilot on and off when pressed once. Turns AutoPilot on when held for two seconds.
- Cruise Control**  
Turns cruise control on and off using the current GPS speed as the target speed.

#### TRACKS

- Track to End**  
Navigates to the nearest location on a previously recorded track and follows it to its end.
- Track to Start**  
Navigates to the nearest location on a previously recorded track and follows it to its start.
- Track Record**  
Starts and ends the recording of a track to a selected memory location.
- Record Pause/Escapes**  
Pauses the recording of a track and then resumes the recording when pressed again.

#### SPOT LOCK

- Spot Lock**  
Turns spot lock on and records it to a memory location.
- Spot Lock Recall**  
Recalls a spot lock location from memory and turns spot lock on.

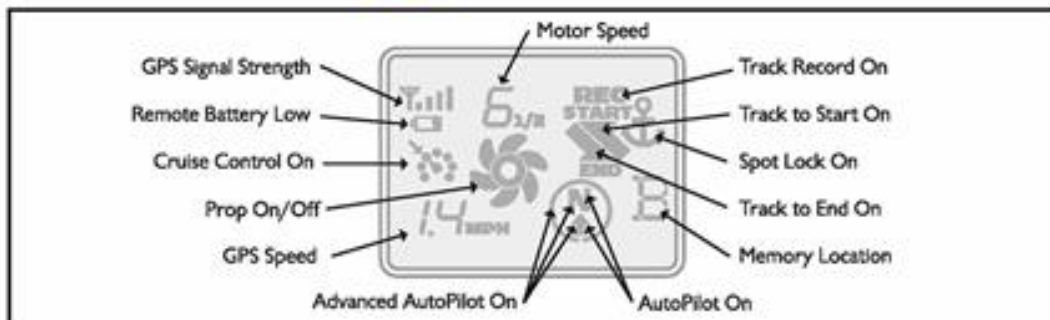

## Quick Reference Guide

### This refers to both i-Pilot remote 1.5 & 1.0

#### ▶ ENGAGING SPOT LOCK

1. Press the **Spot Lock** button on the remote.
2. The Memory Location icon will flash on the remote LCD for three seconds, allowing you to choose a memory location by pressing the **Speed Up** or **Speed Down** buttons. Pressing the **Spot Lock** button again or waiting for three seconds accepts the memory location.

#### ▶ DISENGAGING SPOT LOCK

1. To disengage **Spot Lock** press any of these buttons: **Prop On/Off, Steer Right, Steer Left, Speed Up, Speed Down** or **Spot Lock**.

#### ▶ RE-ENGAGE A SAVED SPOT LOCK LOCATION

1. Manually navigate the boat to within a quarter mile of the saved **Spot Lock** location. Due to safety reasons, i-Pilot will not re-engage a saved **Spot Lock** location greater than a quarter mile away.
2. Press the **Spot Lock Recall** button on the remote.
3. The Memory Location icon will flash on the remote LCD for three seconds allowing you to choose a memory location by pressing the **Speed Up** or **Speed Down** buttons. Pressing the **Spot Lock Recall** button again or waiting for three seconds accepts the memory location.

#### ▶ SPOT LOCK ESCAPE

1. If the **Spot Lock** button is accidentally hit, press the **Record Pause/Escape** button or any manual navigation button within three seconds to cancel the command.

#### ▶ ENGAGING CRUISE CONTROL

1. Press the **Cruise Control** button on the remote.
2. The current GPS speed will flash, displaying your current speed as the target GPS speed on the remote LCD for three seconds.
3. Press the **Speed Up** or **Speed Down** buttons to increase or decrease the target speed or press the **Cruise Control** button again to engage **Cruise Control** immediately.

#### ▶ DISENGAGE CRUISE CONTROL

1. Pressing the **Cruise Control** button will disengage **Cruise Control**.

#### ▶ ADJUSTING TARGET SPEED WITH CRUISE CONTROL ENGAGED

1. With **Cruise Control** engaged press the **Speed Up** or **Speed Down** buttons to adjust the target speed by 0.1 MPH increments.

#### ▶ ENGAGING ADVANCED AUTOPILOT AND AUTOPILOT

1. To engage **Advanced AutoPilot**, press the **AutoPilot** button once. To engage **AutoPilot**, press and hold the **AutoPilot** button for two seconds.
2. The **Advanced AutoPilot** or **AutoPilot** icon will be displayed on the remote LCD.
3. To adjust desired heading, manually steer motor to new heading. i-Pilot will lock onto new heading.

#### ▶ RECORDING A TRACK

1. Press the **Record** button on the remote.
2. The Memory Location icon will flash on the remote LCD for three seconds, allowing you to choose a memory location by pressing the **Speed Up** or **Speed Down** buttons. Pressing the **Record** button again or waiting for three seconds accepts the memory location.
3. The REC icon will be displayed on the remote LCD. Remember this will be the start point on the track.
4. Navigate the boat along the desired path or course. **AutoPilot** and/or **Cruise Control** can be used while recording a track.
5. Press the **Record** button on the remote again to stop the recording. The recording will end automatically if the two-mile distance limit is reached for the track or if one of the following buttons are pressed: **Spot Lock, Spot Lock Recall, Track to End** or **Track to Start**.

#### ▶ PAUSE AND RESUME A RECORDING

1. While recording a track press the **Record Pause/Escape** button.
2. The record icon will flash on the remote LCD.
3. i-Pilot has now paused the recording of the track.
4. If the boat moves farther than a quarter mile from where the **Record Pause/Escape** button was pressed, the recorded track will be ended and saved to the memory location previously selected.
5. When ready to resume recording, navigate the boat just ahead of where the **Record Pause/Escape** button was pushed. Failure to do this may cause erratic play back of a track.
6. Push the **Record Pause/Escape** button.
7. The record icon will stop flashing on the remote LCD.
8. i-Pilot is now recording again and adding to the track that was paused.

#### ▶ REPLAYING A TRACK (TRACK TO START / TRACK TO END)

1. Manually navigate the boat to within a quarter mile of the saved track. Due to safety reasons, i-Pilot will not re-engage a saved track greater than a quarter mile away.
2. Press the **Track to Start** or **Track to End** button on the remote.
3. The Memory Location icon will flash on the remote LCD for three seconds, allowing you to choose a memory location by pressing the **Speed Up** or **Speed Down** button. Pressing the button pressed in step 2 again or waiting for three seconds accepts the memory location.
4. Adjust motor speed to desired setting to engage and navigate track automatically.

#### ▶ RECORD, TRACK TO END AND TRACK TO START ESCAPE

1. If the **Record, Track to Start** or **Track to End** button is accidentally hit, press **Record Pause/Escape** button within three seconds on the remote to cancel the command.

