



MINN KOTA®

For Authorized Service Providers Only

BUILT-IN SONAR REPAIR

BUILT IN DSC (DUAL SPECTRUM CHIRP) 2023-PRESENT

BUILT IN MEGA SIDE IMAGING 2021-PRESENT

BUILT IN MEGA DOWN IMAGING 2020-PRESENT

US2 (UNIVERSAL SONAR 2) 2007-2023



Revised 05/2024

ATTENTION:

Minn Kota has over 1000 Authorized Service Providers, equipped to properly repair your Minn Kota Product. Repairs completed by Authorized Service Providers receive a 90-day warranty which covers the parts and labor of the necessary repair if the paid repair fails. Purchased parts have no warranty and cannot be returned. For additional details on Minn Kota parts warranty, see <https://minnkota.johnsonoutdoors.com/us/support/warranty>. Johnson Outdoors Marine Electronics, Inc. disclaims all warranties, express and implied, except for those set forth at the above link.

NOTICE: You should only use this guide if:

1. The motor has no factory warranty. Improperly performing many of the operations suggested in this guide may void any remaining factory warranty on your Minn Kota product. If the product is within the factory warranty, the product should be delivered to an Authorized Service Provider for Repairs.
2. You have verified correct voltage and amperage to the product. This means more than just checking voltage. The deep cycle batteries must have been load tested and all connections must have been inspected and are clean and tight. Bad deep cycle batteries or loose or corroded connections may not prevent a voltmeter from obtaining a correct reading and those conditions may prevent your Minn Kota product working properly.
3. You have a complete understanding of and access to the necessary tools including a VOM/Volt Ohm Meter/Multi-meter, an Amp Meter capable of approximately 0.1 amp accuracy and reading up to 60 amps DC, and basic hand tools.

⚠ CAUTION!

ALWAYS WEAR SAFETY GLASSES AND GLOVES. DISCONNECT ALL POWER TO THE MINN KOTA PRODUCT BEFORE BEGINNING ANY WORK OR MAINTENANCE. JOHNSON OUTDOORS MARINE ELECTRONICS, INC. IS NOT RESPONSIBLE FOR ANY DAMAGE DUE TO IMPROPER RIGGING OR INSTALLATION. IF YOU DO NOT HAVE THE SKILLS, EXPERIENCE, AND TOOLS TO PERFORM THE LISTED OPERATIONS, SEEK THE HELP OF A MINN KOTA AUTHORIZED SERVICE PROVIDER.

⚠ CAUTION!

READ ALL PRODUCT MANUALS, SERVICE INSTRUCTIONS AND WARNINGS CAREFULLY BEFORE BEGINNING AND DETERMINE WHETHER OR NOT YOU UNDERSTAND AND ARE PREPARED TO COMPLETE THE OPERATION. MINN KOTA TECHNICAL SUPPORT STAFF ARE NOT ABLE TO ASSIST BEYOND THE INCLUDED INSTRUCTIONS. ATTEMPTING THESE REPAIRS AND THEN TAKING THE PRODUCT TO AN AUTHORIZED SERVICE PROVIDER MAY RESULT IN ADDITIONAL TIME FOR THEM TO DIAGNOSE AND REPAIR DISASSEMBLED PRODUCTS (WHICH WILL INCREASE THE COST OF REPAIRS).

Buy Parts Online

Minn Kota and Cannon Parts available at
<https://motors.johnsonoutdoors.com>.



CONTENTS

NOTES	1
ATTENTION:.....	2
TOOLS.....	5
COMMON HAND TOOLS:	5
HISTORY	5
SONAR SPECIFICATIONS	6
BUILT IN DSC (DUAL SPECTRUM CHIRP)	6
BUILT-IN MEGA SIDE IMAGING.....	7
BUILT IN MEGA DOWN IMAGING	8
UNIVERSAL SONAR 2	9
ADAPTER SPECIFICATIONS.....	10
MKR-DSC-10	10
MKR-DSC-12	10
MKR-DSC-14	11
MKR-DSC-15	11
MKR-DSC-16	12
MKR-MI-1	12
MKR-MDI-1.....	13
MKR-MDI-2.....	13
MKR-US2-1	14
MKR-US2-8	14
MKR-US2-9	14
MKR-US2-10	14
MKR-US2-11	15
MKR-US2-12	15
MKR-US2-13	15
MKR-US2-14	15
MKR-US2-15	16
MKR-US2-16	16

REPAIR SCENARIOS.....	17
CASE I. Sonar display blacks out, loses bottom reading, or gives erroneous readings while trolling motor propeller is spinning (operates fine with trolling motor off).....	17
CASE II. Sonar unit not receiving bottom reading with trolling motor ON or OFF.	19
CASE III. Sonar unit losing bottom reading after a certain depth reading.	20
CASE IV. Temperature readings are incorrect.	20
CASE V. Sonar metal connector (adapter plug) getting hot or internal fuse blown.....	22
CASE VI. DSC not recognized by Humminbird Solix or Apex Unit.	23
APPENDIX.....	24
MINN KOTA SONAR VIDEOS	24

TOOLS

COMMON HAND TOOLS:

Slip Jaw Pliers

Volt-Ohm Meter & Amp Meter

Known Good Transducer

Additionally all the tools necessary for working on the motor the sonar is built into will be required.

HISTORY

A trend developed in the 1990s of attaching depth finder transducers to the lower unit of trolling motors. Noting the exposed cable as risk point Universal Sonar was developed. The original Universal Sonar was single beam ~200 kHz transducer that could function with depth finders designed to work from 183 kHz to 210 kHz, connecting to the depth finder via an Adapter.

When Johnson Outdoors Inc. acquired Humminbird an opportunity was created to improve the transducer. This opportunity was realized in 2007 with the release of Universal Sonar 2.

Universal Sonar 2 adds temperature sensing and a dual beam transducer. The dual beams were 83 and 200 kHz. Some units that did not operate right at 200 kHz were no longer compatible; the vast majority of depth finders in common use were still compatible.

In 2020 MEGA Down Imaging became a built in option with MEGA Side Imaging being added in 2021. MEGA Imaging is uniquely Humminbird, these transducers are only compatible with Humminbird Depth Finders. Some Humminbird Depth finders connect directly without an Adapter, Humminbird Helix Units require and Adapter.

Universal Sonar 2 is replaced with Built In Dual Spectrum Chirp in 2023 as the optional “2D” Built In Sonar in Minn Kota Motors. Chirp (Compressed High Intensity Radar Pulse) allows a much more detailed view of the objects below the surface. Humminbird units connect to motors with Built In Dual Spectrum Chirp using the same method as Built In Imaging. Adapter cables are available for many other brands of depth finders, compatibility will be limited and Johnson Outdoors Inc. is not able to fully qualify compatibility as was done with Universal Sonar and Universal Sonar 2.

Built in Sonar is an option on a number of freshwater motor models; built in sonar has not been offered on saltwater motors.



Humminbird
Side Imaging



Humminbird
Dual Spectrum Chirp

SONAR SPECIFICATIONS

BUILT IN DSC (DUAL SPECTRUM CHIRP)

Sonar Type: Humminbird Dual Spectrum Chirp

Optionally Equipped on PowerDrive, Fortrex, Terrova, Ultrex, Ultrerra, Terrova Quest, Ultrex Quest, Ultrerra Quest 2023-

Dual Spectrum Chirp is a Humminbird Transducer. Adapter Cables are available, actual compatibility is subject to depth finder manufacture’s specifications.



NOTICE: When equipped on an 55 pound thrust Terrova Unit it is not possible to replace just the transducer. If a repair requires transducer replacement, replace the Lower Unit and Tube Assembly.

Extending the output cable to move the depth finder further away from the motor than the included cable allows should be done with the Humminbird Accessories for extending Solix/Apex transducers and connect any adapters at the end of that extension. If using a Helix connect the adapter at the end of the Solix/Apex Extension.



- 720106-1 EC M3 14W10 – 10’ Transducer Extension Cable
- 720106-2 EC M3 14W30 – 30’ Transducer Extension Cable

Depending on the motor, the cable connecting from the control box to the base of the motor will be either 490575-2 or 490575-3. These cables only differ from each other in length and are diagramed below.

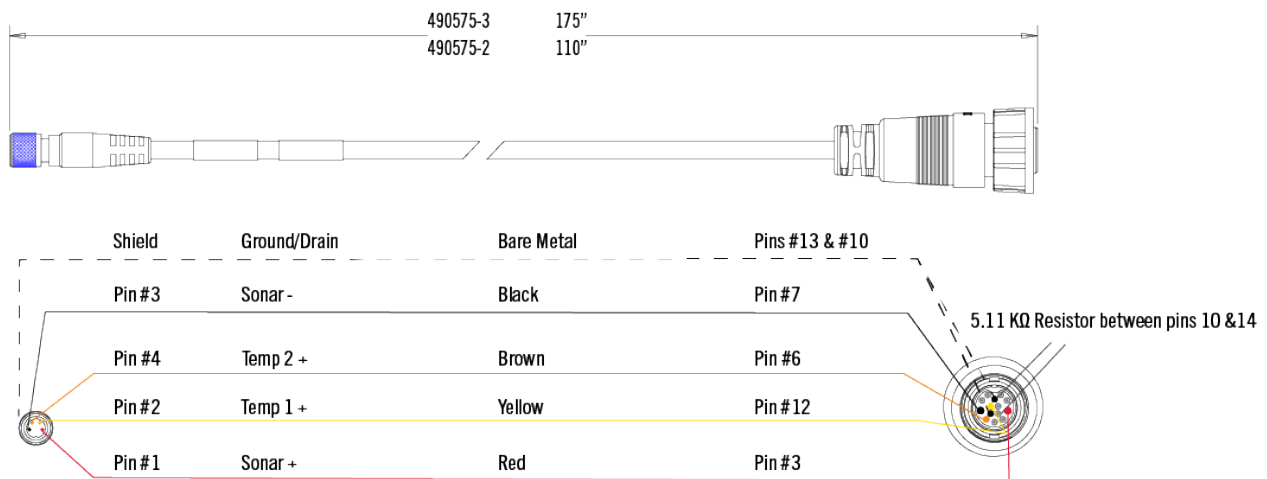

BUILT-IN MEGA SIDE IMAGING

Sonar Type: Humminbird MEGA SI+, DI+, Dual Spectrum Chirp w/Temp

All Operating frequencies normally available to Humminbird Units with MEGA Imaging

Optionally equipped on Terrova Quest, Ultrex Quest and Ulterra Quest Motors 2023-

Optionally equipped on Ultrex BT and Ulterra BT Motors 2020-2023

Compatible with Humminbird Mega Side Imaging equipped Helix 8 and up*, G2 and Later, All Mega Side Imaging Equipped Solix Units, and All Apex units.

*Helix units require Adapter Cable MKR-MI-1 Item #1852088



NOTICE: When Equipped on an 80 pound thrust Terrova BT, Ultrex BT, or Ulterra BT Unit it is not possible to replace just the transducer. If a repair requires transducer replacement, replace the Lower Unit and Tube Assembly.

Extending the output cable to move the depth finder further away from the motor than the included cable allows should be done with the Humminbird Accessories for extending Solix/Apex transducers. If using a Helix connect the adapter at the end of the Solix/Apex Extension.

- 720106-1 EC M3 14W10 – 10' Transducer Extension Cable
- 720106-2 EC M3 14W30 – 30' Transducer Extension Cable



The output cable connected in the control box is 490516-3, diagramed below:

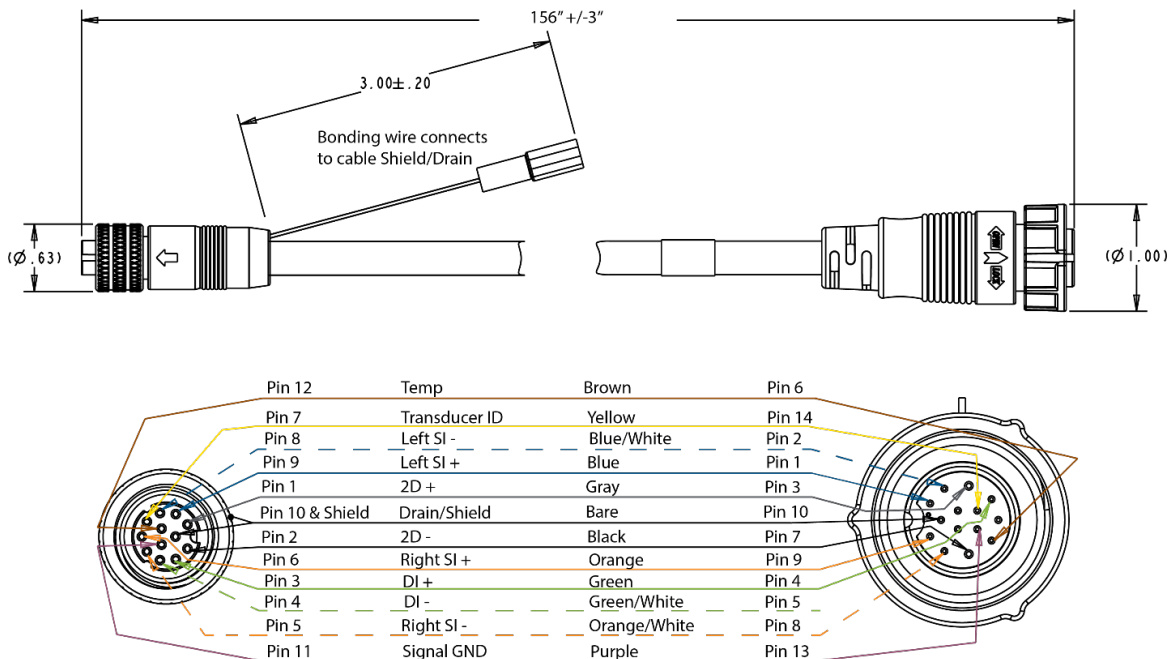

BUILT IN MEGA DOWN IMAGING

Sonar Type: Humminbird MEGA DI+, Dual Spectrum Chirp w/Temp

All Operating frequencies normally available to Humminbird Units with MEGA Imaging

Optionally Equipped Non-Quest Ultrex 2023-, Non-Quest Ulterra 1.5 2023-, and Non-Quest Terrova 2.5 2023-.

Optionally Equipped on Fortrex 2019-2021, Terrova BT 2019-2023, Ulterra BT 2019-2023, Ultrex BT 2019-2023,

Compatible with Humminbird Mega Down Imaging equipped Helix 7* and Up**, G2 and Later, All Mega Down Imaging Equipped Solix Units, and All Apex units.

*Helix 7 units require Adapter MKR-MDI-2 Item #1852086

**Helix 8 and Up Units require Adapter Cable MKR-MI-1 Item #1852088 or MKR-MDI-1 (no longer available)



NOTICE: When Equipped on an 80 pound thrust Terrova BT, Ultrex BT, or Ulterra BT Unit it is not possible to replace just the transducer. If a repair requires transducer replacement, replace the Lower Unit and Tube Assembly.

Extending the output cable to move the depth finder further away from the motor than the included cable allows should be done with the Humminbird Accessories for extending Solix/Apex transducers.

- 720106-1 EC M3 14W10 – 10' Transducer Extension Cable
- 720106-2 EC M3 14W30 – 30' Transducer Extension Cable



Depending on the motor, the cable connecting from the control box to the base of the motor will be either 490507-1 or 490507-2. These cables only differ from each other in length, and are diagramed below.

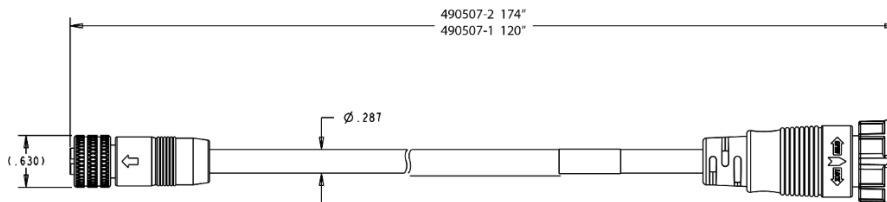

UNIVERSAL SONAR 2

Sonar Type: 83/200 kHz transducer with Temperature probe

Optionally Included on most freshwater bowmount permanent magnet motor families from 2007-2023

Compatible with most fishfinders via an adapter cable

NOTICE: When Equipped on an 55 pound thrust Terrova or Terrova BT Unit it is not possible to replace just the transducer. If a repair requires transducer replacement, replace the Lower Unit and Tube Assembly.



Extending the output cable to move the depth finder further away from the motor than the included cable allows can be accomplished with the accessory MKR-US2-11 or by using additional motor extensions

- | | | |
|----------------------------------|---------|-----------|
| • MKR-US2-11/1852080 | 2211410 | Accessory |
| • Electric Steer Extension Cable | 2211415 | Part 110" |
| • Cable Remote Extension Cable | 2211410 | Part 175" |
| • Ultrex Extension Cable | 2211410 | Part 175" |



ADAPTER SPECIFICATIONS

NOTICE: Adapter Cables are not stocked as parts, and cannot be ordered via the parts portal. Cable P/N is supplied as a reference only, if a cable has a label/tag the reference number on that label/tag will be the Cable P/N rather than the Accessory Item #.

MKR-DSC-10

Item #1852077

Cable P/N 2372077

Lowrance 7-Pin

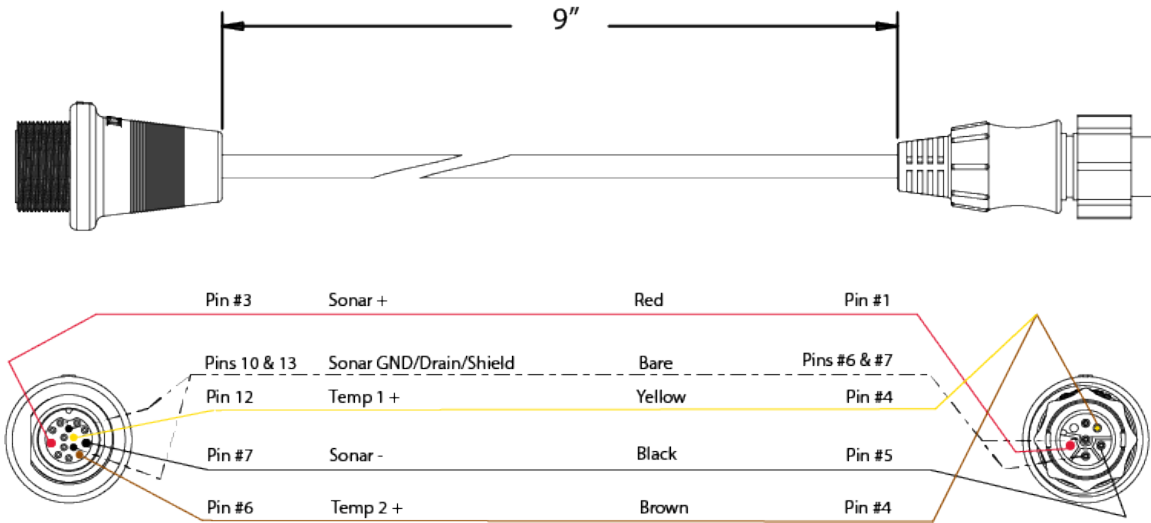

MKR-DSC-12

Item #1852081

Cable P/N 2372081

Garmin 4-Pin (Echo)

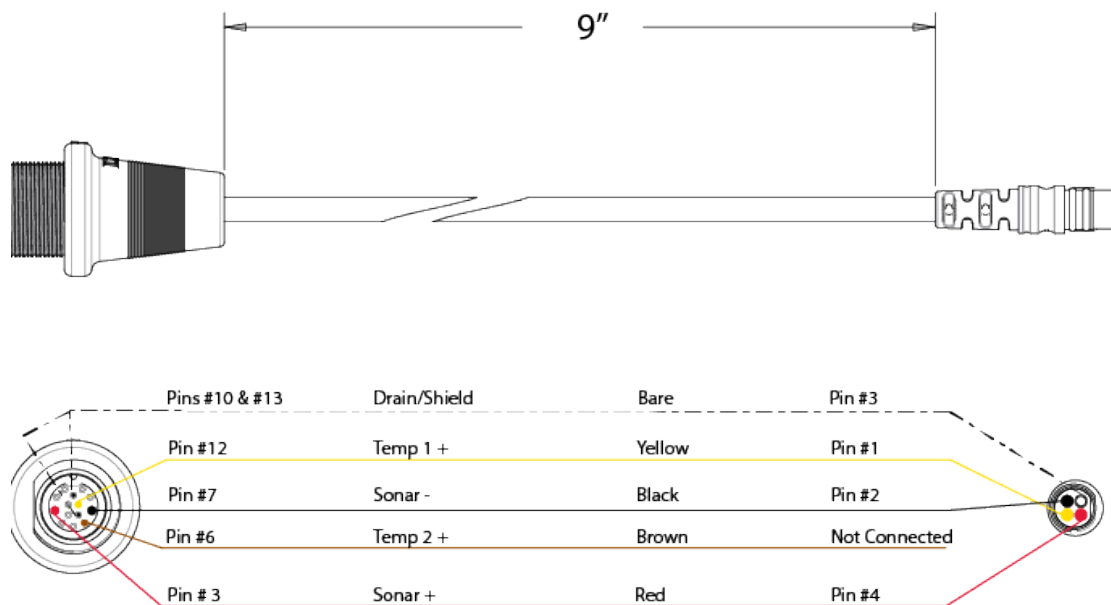

MKR-DSC-14

Item #1852082

Cable P/N 2372082

Garmin 8-Pin

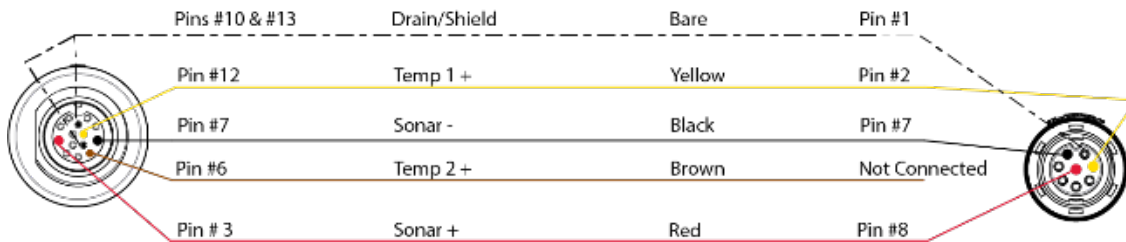
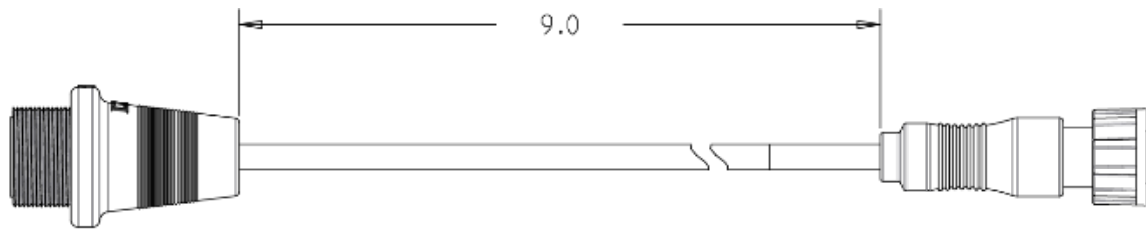

MKR-DSC-15

Item #1852078

Cable P/N 2372078

Lowrance 8-Pin (Triple Shot)

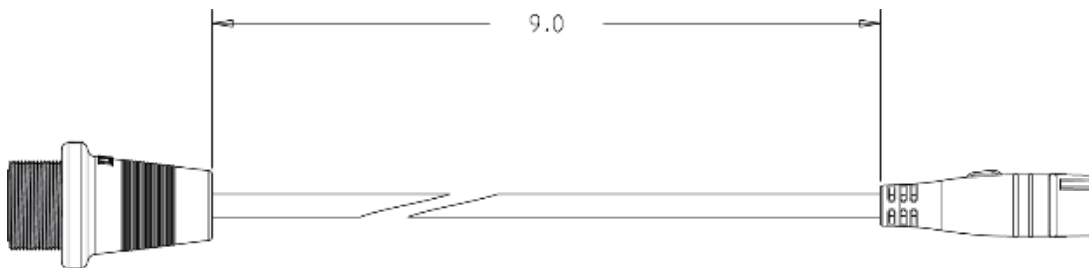

MKR-DSC-16

Item #1852079

Cable P/N 2372079

Lowrance 9-Pin (Total Scan)

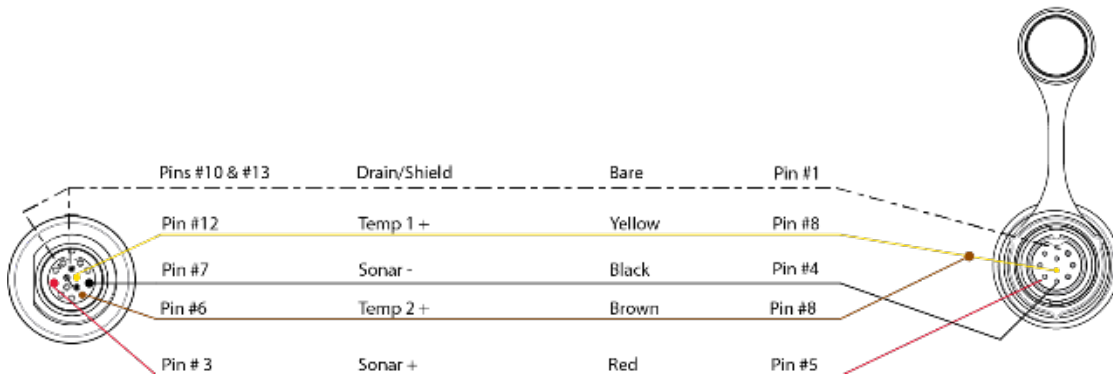
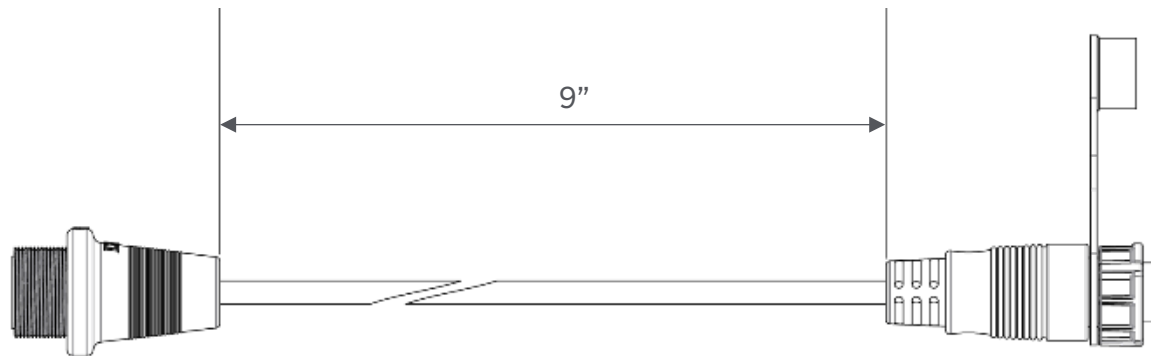

MKR-MI-1

Item #1852088

Cable P/N 490537-2

Adapter Cable, Built in Mega Side Imaging or Built in Mega Down Imaging or Built In DSC to Compatible Humminbird Helix 8-15

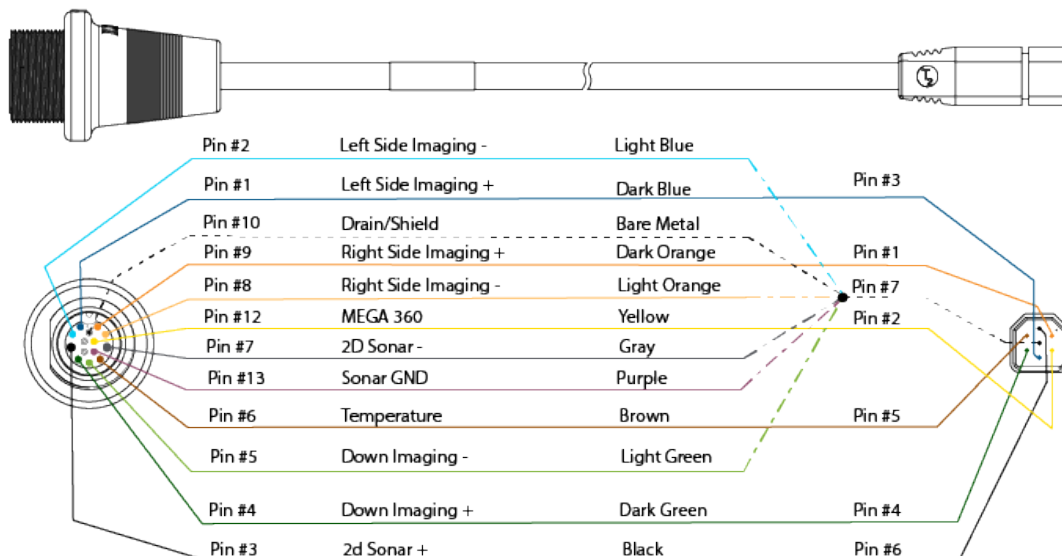

MKR-MDI-1

Item #1852085 Cable P/N 490506-1

Adapter Cable, Built in Mega Down Imaging to Compatible Humminbird Helix 8-15

Discontinued 2021 with release of Built in Mega Side Imaging. The MKR-MI-1 works for all cases that could use this cable, this cable is not compatible with Side Imaging.

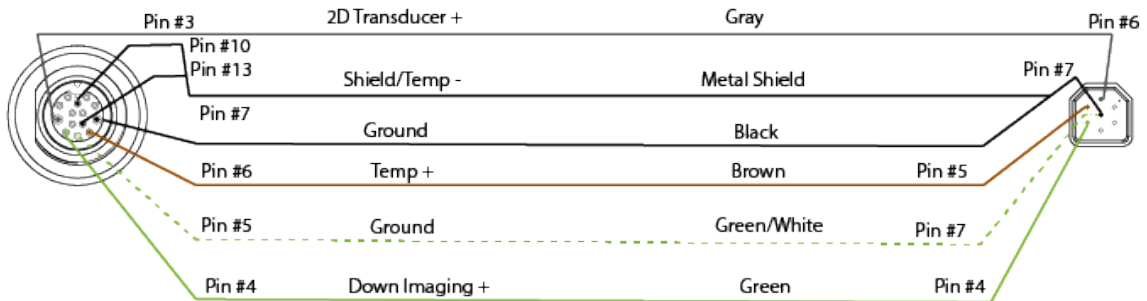
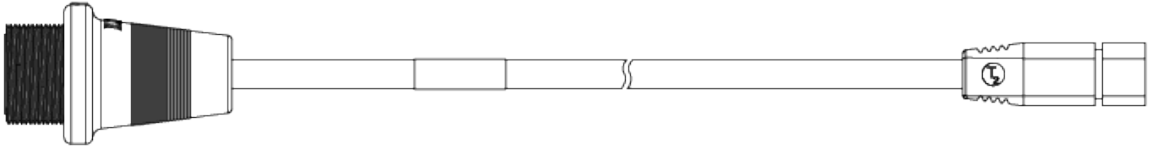

MKR-MDI-2

Item #1852086 Cable P/N 490518-1

Adapter Cable, Built in Mega Down Imaging or Built in DSC to Compatible Helix 7

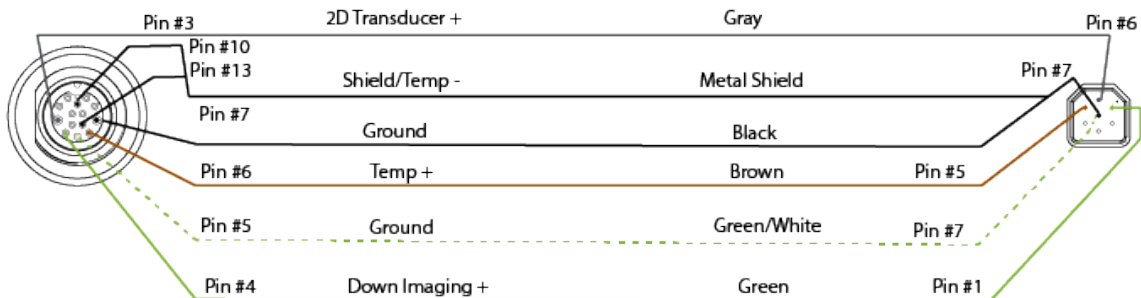
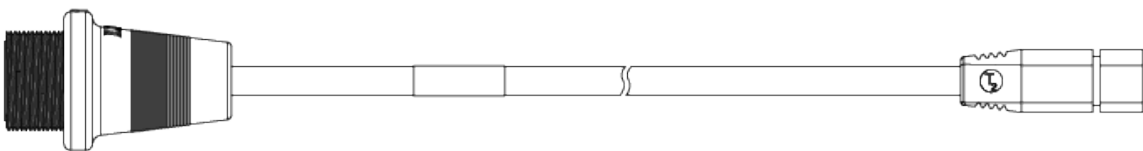

MKR-US2-1

Item #1852061 Cable P/N 2372061

Adapter Cable, Universal Sonar 2 to Garmin

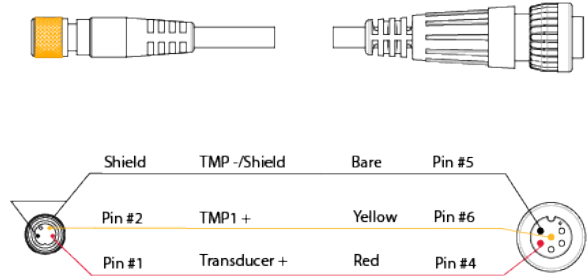

MKR-US2-8

Item #1852068 Cable P/N 2372068

Adapter Cable, Universal Sonar 2 to Humminbird 7 Pin

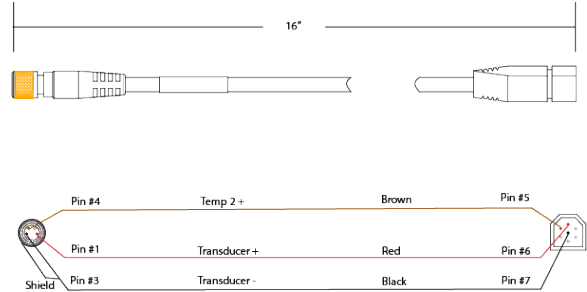

MKR-US2-9

Item #1852069 Cable P/N 2372069

Adapter Cable, Universal Sonar 2 to Lowrance/Eagle 6 Pin

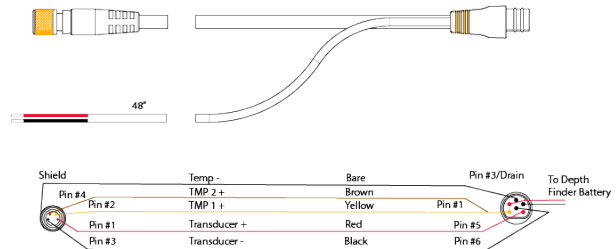

MKR-US2-10

Item #1852060 Cable P/N 2372070

Adapter Cable Universal Sonar 2 to Lowrance 7 Pin Blue Connector.

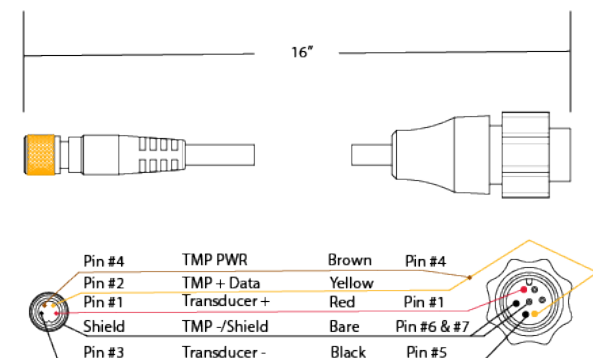

MKR-US2-11

Item #1852080 Cable P/N 2211410

Universal Sonar 2 11' Extension Cable



MKR-US2-12

Item #1852072 Cable P/N 2372072

Adapter Cable, Universal Sonar 2 to Garmin Echo

NOTICE: January 2022 the ribs on the Garmin end of the adapter were reduced in diameter from 0.378" to 0.372". This was to correct a fit issue with some Garmin Units.

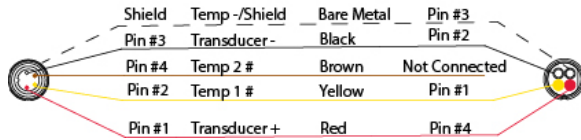
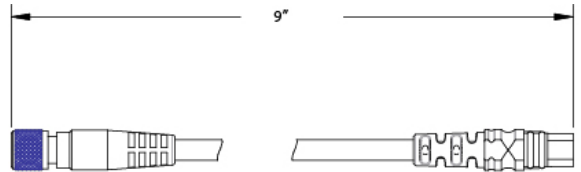

MKR-US2-13

Item #1852073 Cable P/N 2372073

Adapter Cable, Universal Sonar 2 to Humminbird Apex/Solix/Onix

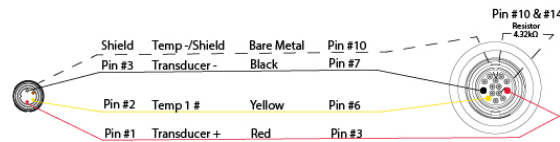
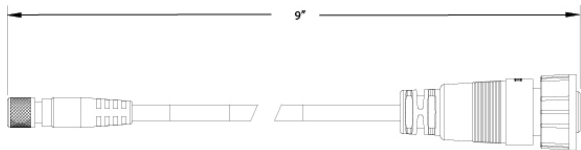

MKR-US2-14

Item #1852074 Cable P/N 2372074

Adapter Cable, Universal Sonar 2 to Garmin 8 Pin



NOTICE: Locking Collar is included as a bag assembly with instructions, and is not installed on the cable as it is shipped.

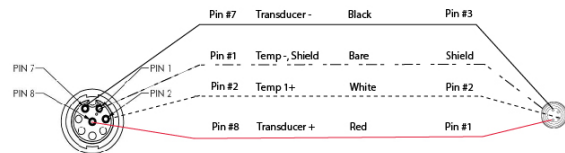
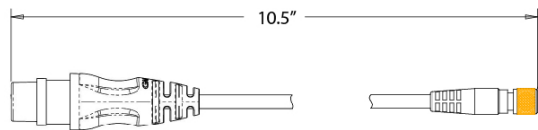

MKR-US2-15

Item #1852075 Cable P/N 2372075

Adapter Cable, Universal Sonar 2 to Lowrance Hook2

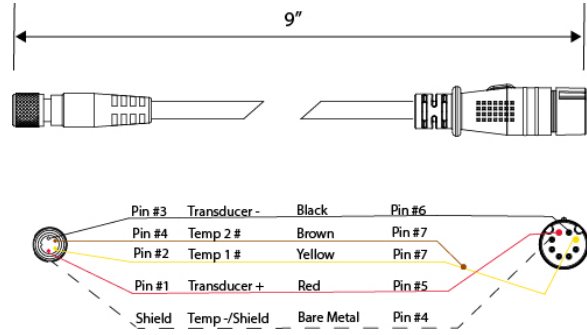
MKR-US2-16

Item #1852076 Cable P/N 2372076

Adapter Cable, Universal Sonar 2 to Lowrance Elite Ti2 & HDS

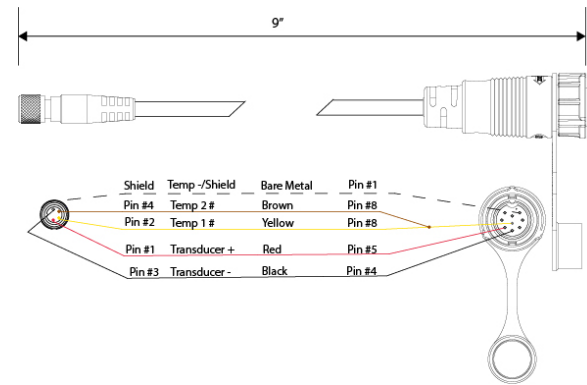

REPAIR SCENARIOS

CASE I. Sonar display blacks out, loses bottom reading, or gives erroneous readings while trolling motor propeller is spinning (operates fine with trolling motor off).

NOTICE: This is an indication of interference, not a faulty transducer! Interference can only be evaluated correctly while the boat is on-the-water.

Step 1. Consumer should refer to the user's manual for the sonar display configuration options.

A. Consumer should verify the sonar is running the most current software for their unit. (The sonar manufacturer website may have downloadable upgrades.)

B. Many sonar displays have noise reduction options within their menus. (Humminbird has a "Noise Filter" under the Sonar tab menu.)

C. Reduce gain of sonar display until an adequate display is visible.

D. Humminbird has a power cable for their sonar units with a built-in ferrite choke. This comes standard on current Humminbird Side-Imaging and Down-Imaging units. (p/n 490332-2)

Step 2. Check supply voltage and wiring.

A. Determine if supply voltage for trolling motor and depth finder is provided by the same battery.

A-1. If yes, disconnect depth finder battery leads from the trolling motor battery and connect them to the engine cranking battery.

B. If boat has a multi-channel on-board charger that is connected to both the crank battery and trolling motor battery(s), temporarily disconnect the on-board charger output leads to the crank battery and test for interference.

B-1. If the interference is reduced or eliminated use choke cable p/n 490482-1 on charger output leads to the crank battery.

C. Check the routing of the depth finder and trolling motor battery leads.

C-1. If they run parallel to each other for any length of distance, separate the leads as much as possible or run the leads to the trolling motor and depth finder on opposite sides of boat.

C-2. Excess lengths of power or transducer cables should not be coiled! They should be wrapped in a figure 8 pattern.

Step 3. Check connections:

A. Verify all the transducer plug connections are secure (in control box, at the adapter cable, and at sonar). The proper torque procedure in the field is:

A-1. Loosen the connectors. Next, using your fingers only, tighten the connectors to a reasonable level.

A-2. Draw a line straight across both connector halves.



A-3. Using appropriate slip-joint pliers or similar tools, grasp each connector half. Using the above drawn line as a reference, tighten the connectors an additional $\frac{1}{4}$ of a turn. (see picture on next page)

B. Check to make sure the internal fuse (in the control box) has not blown. See Case V of this manual for an explanation as to why this fuse has blown.

Step 4. Check the lower unit:

A. Inspect for water in the lower unit.

B. The brush shunt wire may be inadvertently touching the inside of the motor case. This is more apt to happen on 4" & 4 ½" motor assemblies, after the lower unit has been opened for repairs.

C. Check motor timing for potential excess brush arcing:

C-1. On 4" & 4 ½" motor assemblies check to ensure the skeg on the rear endbell is in-line (parallel with) the composite shaft of the trolling motor.

C-2. On smaller motors (skeg on front end bell), check to ensure the timing/witness mark on the magnet section is aligned with the skeg. An offset magnetic field can cause additional brush arcing and interference.

Step 6. On DSC or US2 equipped PowerDrive and Terrova models thread a ferrite bead (p/n 2887313) onto the motor leads as close as possible to the control board (inside the speed control cover).

A. Disconnect the red and black (motor + and motor -) coil cord wires from the control board.

- B. Slide the ferrite bead over the red and black coil cord wires.
- C. Reconnect the red and black coil cord wires to their appropriate pins on the control board.

Step 7. If interference is still present then add the Ferrite Ring (p/n 470085-1) to the extension cable.

CASE II. Sonar unit not receiving bottom reading with trolling motor ON or OFF.

NOTICE: Imaging Transducers will only return a blank screen if not in the water.

Step 1. Verify Compatibility. Check the current compatibility chart (QR Code/Link), make sure the unit is listed as compatible and the correct adapter is being used (if applicable).



www.minnkotamotors.com/support/compatibility

NOTICE: Built in DSC is a Humminbird Transducer. Johnson Outdoors cannot verify or ensure compatibility with specific depth finders from other manufacturers. The adapters connect to the appropriate elements in the transducer but full functionality is dependent on the depth finder manufacturer

Step 2. Ensure this is not a cross-talk situation with another transducer on the boat transom. Instruct the customer to turn off all other sonar units when operating the DSC, BIMDI, BIMSI or US2 for testing purposes to see if the situation is corrected.

Step 3. Is the DSC, BIMDI, BIMSI or US2 transducer pinging? (Do you hear or feel the pinging when you put your ear close to the transducer?)

- A. If Yes the transducer is operating correctly.
- B. If no, test the sonar with the original transducer that came with the sonar unit to determine if the sonar unit is faulty or if the Built-In Transducer is at fault.
 - a. If the sonar works properly with the original or “known good” transducer proceed to Step 4.
 - b. If sonar still does not receive a bottom reading problem lies in the sonar unit, consumer will need to work with the sonar manufacturer for service.

Step 4. Inspect the adapter cable and extension cable for any sign of being cut/pinched/damaged. Replace cables that show signs of damage and retest. If no visible cable damage or issues persist after replacing all damaged cables proceed to Step 5.

Step 5. For DSC, BIMDI, BIMSI or US2 units that have 112# thrust, replace the front-end bell/transducer assembly on the motor. For DSC or US2 units with 80# Thrust replace the

front-end bell/transducer assembly. For BIMDI & BIMSI units that have 80# thrust it will be necessary to replace the complete Lower Unit/Shaft Assembly. (There is a ferrite bead inside the composite shaft that is threaded onto the brush leads which necessitates this.) For 55# thrust Terrova models, replace the complete Lower Unit/Shaft Assembly.

CASE III. Sonar unit losing bottom reading after a certain depth reading.

- Step 1.** Customer should test with the trolling motor not running (prop off) at the depth where the problem is occurring.
- A.** Ensure this is not a cross-talk situation with another transducer on the boat transom. Instruct the customer to turn off other sonar units when operating the DSC, BIMDI, BIMSI and US2 for testing purposes to see if the situation is corrected.
 - B.** If the sonar bottom reading is correct with the trolling motor off, this is interference. See [CASE I. Sonar display blacks out, loses bottom reading, or gives erroneous readings while trolling motor propeller is spinning \(operates fine with trolling motor off\). on page 17](#), for ideas on addressing this interference issue.
 - C.** If the sonar still has a problem losing the bottom reading even with the trolling motor off, suspect faulty transducer.
 - C-1.** For DSC, BIMDI, BIMSI or US2 units that have 112# thrust, replace the front-end bell/transducer assembly on the motor. For DSC or US2 units with 80# Thrust replace the front-end bell/transducer assembly. For BIMDI & BIMSI units that have 80# thrust it will be necessary to replace the complete Lower Unit/Shaft Assembly. (There is a ferrite bead inside the composite shaft that is threaded onto the brush leads which necessitates this.) For 55# thrust Terrova models, replace the complete Lower Unit/Shaft Assembly.

CASE IV. Temperature readings are incorrect.

- Step 1.** Verify the sonar unit is on the current US2, BIMDI, or BIMSI compatibility list, that the correct adapter cable is being used, and all plug connections are secure (in the control box and at the adapter cable).
- Step 2.** Check the resistance reading across the pins connected to the Thermistor (temperature dependent resistor) in the Transducer.

FOR US2 UNITS:

See [Figure 1](#) below. Measure the resistance from the thermistor pins to the transducer cable connector (shield) one at a time. (Pin 2 to shield 5 and then Pin 4 to shield 5.)

- A-1.** The shield wire is used as an active ground for the thermistor signals so verify the metallic connectors on the US2 cables are ¼ turn past finger-tight.

NOTICE: For troubleshooting the transducer cable, it may be easier to sacrifice a cable to make a “pigtail” rather than try to hold your VOM probes on the tiny pins. Take either an extension cable (female end) or any US2 adapter cable and cut the cable approximately 5 inches from the cable end. Strip the 4 conductors. You now have access to the following colored wires: red – pin 1 (transducer +), black – pin 3 (transducer -), yellow – pin 2 (thermistor +), brown – pin 4 (thermistor -) and shield.

- A. The resistance at normal room temperature (approximately 70° F) should be between 10.5K-13.5K ohms for each of the two temp pins. (The reading will vary slightly as the ambient room temp varies.) The transducer is defective and needs to be replaced if the readings do not fall within this range at normal room temperature.

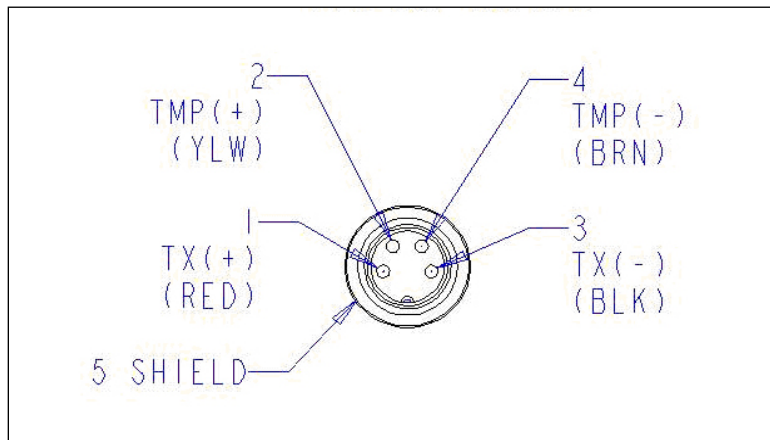

Figure 1

For Built-In Mega Down Imaging, Mega Side Imaging, and Dual Spectrum Chirp:

- A. See Figure 2 below. Measure the resistance from the Temperature + to the Signal Ground.
- B. The resistance at normal room temperature (approximately 70° F) should be between 10.K-12.5K ohms. The reading will vary slightly as the room temperature varies. The transducer is faulty and will need to be replaced if the reading does not fall with this range.
- C. For BIMDI & BMSI units that have 112# thrust, replace the front-end bell / transducer assembly on the motor. For BIMDI & BMSI units that have 80# thrust it will be necessary to replace the entire lower unit assembly and the composite shaft. (There is a ferrite bead inside the composite shaft that is threaded onto the brush leads which necessitates complete lower unit replacement.)

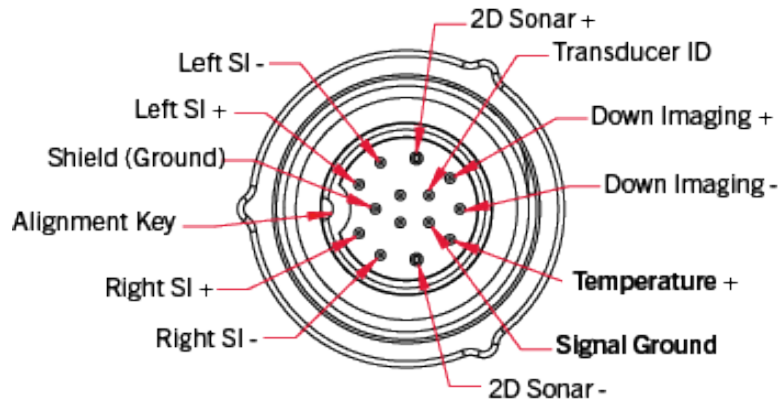
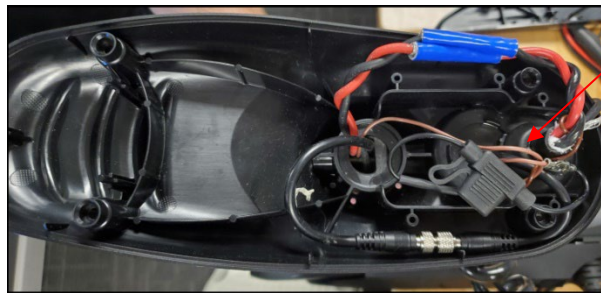

Figure 2

CASE V. Sonar metal connector (adapter plug) getting hot or internal fuse blown.

Built-In Sonar motors have internal bonding/grounding wire connections to eliminate depth finder interference. This internal bonding/grounding wire links the trolling motor negative to depth finder battery negative (starting battery negative). The combination of the Built-In Sonar motor's internal bonding and the external ground connections could cause a shorted condition. This could result in damage to the motor that would not be covered by Minn Kota's warranty.

We have received a few calls regarding the metal connector (adapter plug) getting hot, the 3-amp fuse blowing, and/or rapid electrolysis on the motor lower unit.



You can trace this to one of the following situations:

- A. Depthfinder hooked to trolling motor battery. (The depthfinder needs to be powered by the crank/starting or a separate "house" battery.)
- B. The use of a DC alternator charger. (Some of these chargers link the trolling motor battery negative post to the starting battery while operating the outboard motor).
- C. The use of one of the trolling motor batteries (on 24-volt or 36-volt motors) to provide power to start a "kicker" outboard motor.
- D. The use of a battery selector switch to connect one of the trolling motor batteries (24/36-volt models) to the starting battery.

- E. The brush shunt wire may be inadvertently touching the inside of the motor case. (This is more apt to happen on 4" & 4 ½" motor assemblies after the lower unit has been opened during field repairs.)

NOTICE: To address these issues caused by improper boat wiring, an internal fuse to the motor bonding/grounding wire was added late in the first year of production of the US2 (late AH serial numbers). If the fuse blows, the depth finder may be subject to interference issues. A blown fuse also indicates that one of the above conditions exists and must be corrected prior to replacing the fuse (3-amp, mini automotive).

CASE VI. DSC not recognized by Humminbird Solix or Apex Unit.

When a Solix/Apex does not properly detect a transducer, the unit will disable the pinging of the transducer. The component for transducer identification is in the cable that extends from the Motor Control Box to the depth finder (490575-2, CABLE, ADPTR, 14 PIN, 175"-DSC or 490575-3, CABLE, ADPTR, 14 PIN, 110"-DSC). Prior to replacing the Transducer suspect the extension cable. With the cable disconnected at the Motor Control Box only Pins 10 (2D Sonar +) and 14 (Signal Ground) should have connection with 5.11 kΩ of resistance between them. If connections exist between any of the other pins, or the resistance value differs by more than 0.05 kΩ or 50 Ω replace the extension cable.

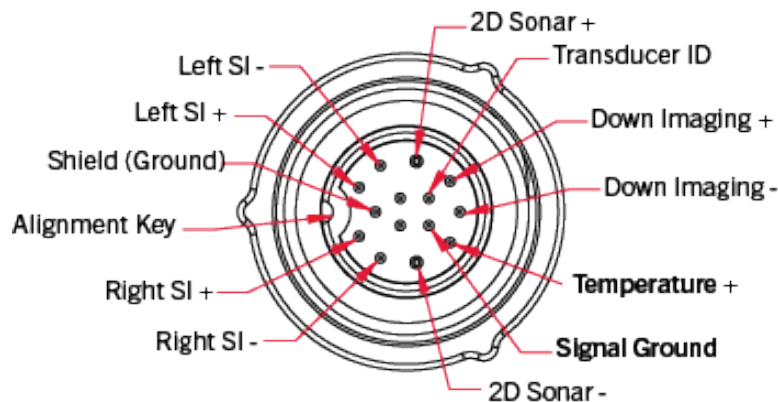

If the Extension Cable tests good the issue may be the Transducer Assembly or the Solix/Apex. Test the Transducer by connecting a known good depth finder to it or Test the Solix/Apex by connecting the Unit to a known good transducer. If the Transducer is suspected bad replace the transducer assembly in the Motor, if the unit is suspect contact Humminbird Customer Service to arrange repair of the Solix/Apex Unit.

NOTICE: Fortrex, Ultrex, and Ultrex Quest motors equipped with DSC, manufactured prior to 17 May 2024 were likely built with an incorrectly assembled 490575-2, CABLE ADPTR, 14 PIN, 175"-DSC, causing the failure. See MSB20240520 for more information.

APPENDIX

MINN KOTA SONAR VIDEOS



MEGA Down Imaging
w/Jason Halfen



Built in MEGA Imaging
w/Chris Zaldain



Built in MEGA Side Imaging
w/Jason Halfen